



## Key Features

- Maintenance Free
- Lightweight Construction
- U, V, W, SOS & Sonic Temp Output
- 20Hz or Optional 32Hz Data Rate
- Optional Analogue Inputs and Outputs

## Specification

### Wind Speed

Range	0 - 45 m/s
Resolution	0.01 m/s
Accuracy*	<1.5% RMS @12 m/s
Accuracy*	<1% RMS @12 m/s (Custom)

### Direction

Range	0 - 359°
Resolution	0.1°
Accuracy	2° @12 m/s
Accuracy	0.5° @12 m/s (Custom)

### Sonic Temperature

Range	-40°C to +70°C
Resolution	0.01°C

### Speed of Sound

Range	300-370 m/s
Resolution	0.01 m/s
Accuracy	< ±0.5% @ 20°C

### Measurement

Internal sample rate	20 Hz or 32 Hz
Output Parameters	1, 2, 4, 8, 10, 16, 20 & 32 (Option) Hz
Units of Measure	m/s, mph, kph, knots, ft/min
Formats	UVW, Polar or NMEA
Averaging	Flexible 0-3600 s

The new WindMaster three axis anemometer is a robust instrument based on time of flight measurements and is essential in the understanding of turbulent flows, surface energy balance and scalar fluxes.

All these areas of research rely on accurate and precise measurements of mean and variance of (time averaged) wind velocities and Speed of Sound (SOS) derived temperature.

This is particularly true in determining scalar fluxes using the eddy covariance technique. Gill employs the optimum mechanical configuration and electronic processing to minimise flow distortion and transducer shadow effects. Gill undertakes an individual calibration with a Gill wind tunnel test on each unit to provide the optimum performance. The WindMaster is available with a 20Hz data output rate with an option to increase this to 32Hz. The instrument is constructed in the familiar Aluminium/carbon fibre construction. The WindMaster is fitted with field proven standard Gill transducers with the ability to measure a top wind speed of 45 m/s.

Both software and electronics have been enhanced to provide improved vertical (W) resolution and SOS accuracy.

New design electronics has facilitated a reduction in power consumption to 55 mA at 12 V dc, a significant advantage when used on power sensitive sites.

A number of orderable options are available including -

- Increase in data output rate to 32 Hz
- 4 analogue output channels with options for 12 or 14 bit resolution.
- 4 analogue input channels, with options for 12 or 14 bit resolution.
- A flange mounting arrangement is provided as standard, with option to order a different mounting.
- Wind tunnel calibration in accordance with ISO 16622 and traceable to national standards.
- Travelling case

### Digital Output

Communication	RS232, 422, 485
Baud Rates	2400 - 115200
Format	ASCII

### Analogue Outputs - Optional

Resolution 12 bits or 14 bits	4 channels available
Selectable Range	User selectable full scale wind speed
Output type	0-20mA, 4-20mA, 0-5V, ±2.5V, ±5V

### Analogue Inputs - Optional

Resolution 12 bits or 14 bits	Up to 4 single ended or 2 differential
Input Type	±5V

### Power Requirement

Anemometer	9-30V DC (25mA @ 12V DC)
------------	--------------------------

### Mechanical

Weight	1.0 kg
Size	750mm x 240mm

### Environmental

Protection Class	IP65
Operating Temp	-40°C to +70°C
Humidity	< 5% to 100% RH
Precipitation	Operation to 300 mm per hour
EMC	Emissions BS EN 61000 - 6 - 3 Immunity BS EN 61000 - 6 - 2

\*Accuracy spec applies for wind speed, and for wind incidence up to ±30° from the horizontal

## Typical Applications

- Meteorological Systems
- Transport Safety
- Structural Safety
- Wind Profiling
- Marine Research
- Wind Turbine Site Survey



## Dimensions

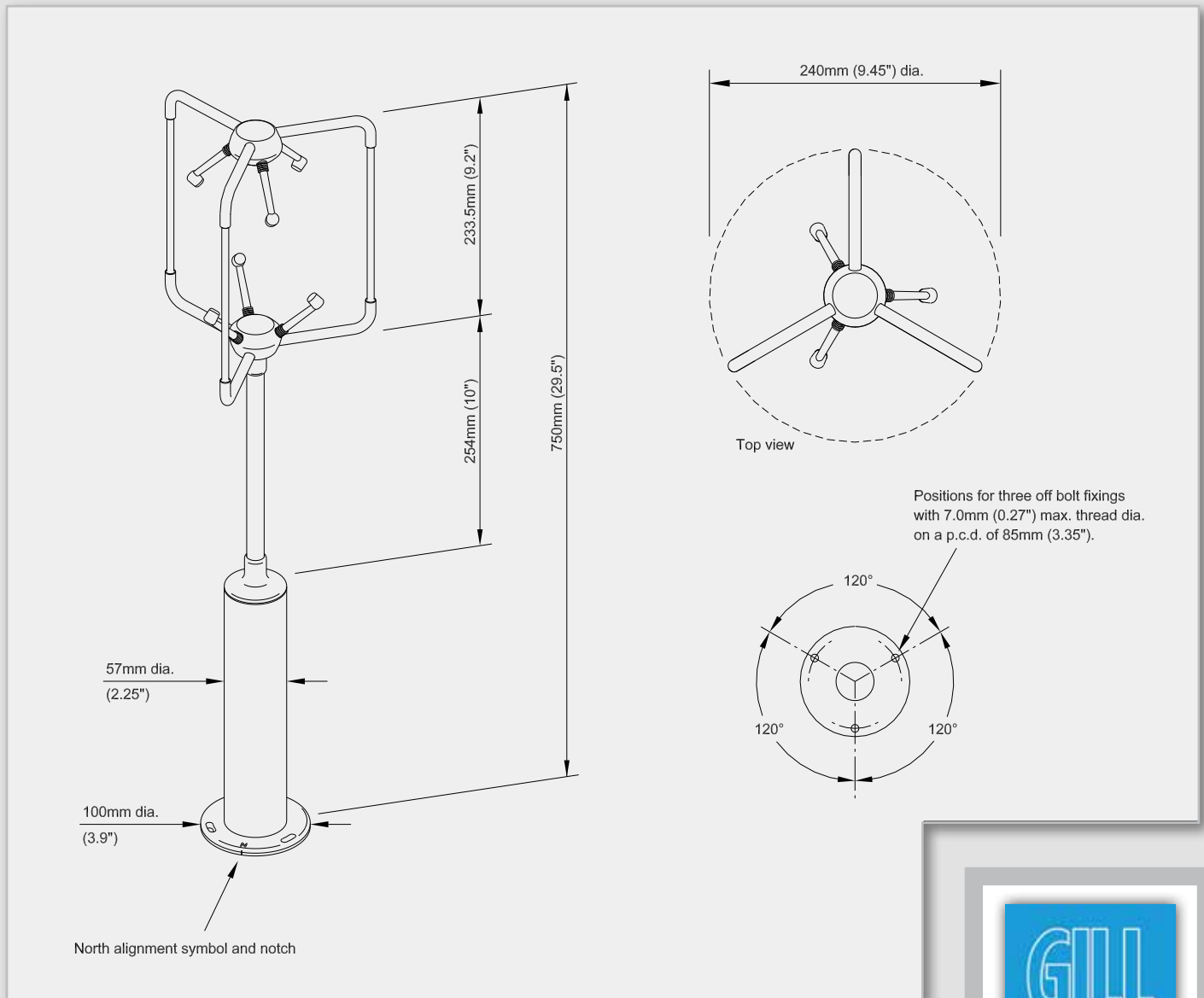

The WindMaster is part of the Solent range of ultrasonic anemometers. The range is in continuous development and therefore specifications may be subject to change without prior notice.

